

# Product Information



## 7044XSX150R26-28S45

EAN 4031582342321

Swivel castor with central, total or directional lock, Frame made of stainless steel, precision ball bearing in swivel head, housing cover made of synthetic plastics, washable. Wheel centre made of Polyamide, electric conductive, Tread made of injected Polyurethane, with threadguards, precision ball bearing, sealed., stem with cam hole for profile bars Washable castors must be sealed in the fitting area by the hospital bed manufacturer.

Technical Data	
Wheel diameter	150 mm
Width of Tread	32 mm
Bolt-Ø	28 mm
Bolt length	96 mm
Offset	40 mm
Swivel Interference	230 mm
Overall height	183 mm
Temperature	- 30 / + 80 °C
Standard	EN 12531
Weight	1.125 kg
Load capacity	150 kg
Load capacity (static)	300 kg
Swivel Radius	115 mm
Hardness of tread	D 40 Shore

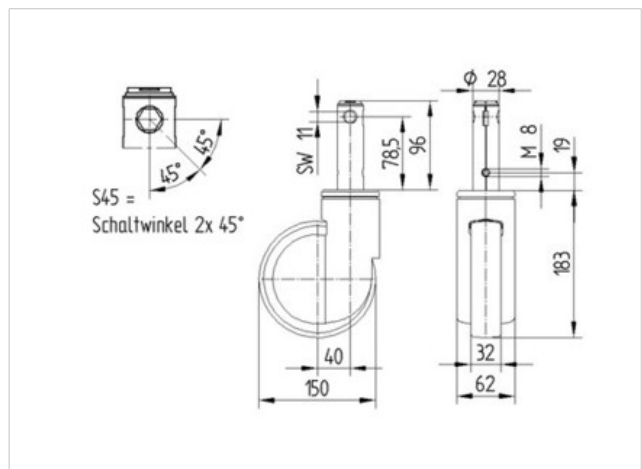

Roll performance	+	+	+	+	+
Movement noise	+	+	+	+	+
Attrition	+	+	+	+	+
Corrosion resistance	+	+	+	+	+

