

Product Information



2944XSX125R26-28S45

EAN 4031582341911

Swivel castor with central, total or directional lock, Frame made of pressed steel, precision ball bearing in swivel head, housing with synthetic cover. Wheel centre made of Polyamide, electric conductive, Tread made of injected Polyurethane, with threadguards, precision ball bearing, sealed., stem with cam hole for profile bars

Hint:TÜV Süd certified product.Washable castors must be sealed in the fitting area by the hospital bed manufacturer.



Technical Data	
Wheel diameter	125 mm
Width of Tread	12 mm
Castor width	60 mm
Bolt-Ø	28 mm
Bolt length	96 mm
Offset	37.5 mm
Swivel Interference	200 mm
Overall height	150 mm
Temperature	- 30 / + 80 °C
Standard	EN 12531
Weight	1.483 kg
Load capacity	125 kg
Load capacity (static)	250 kg
Swivel Radius	100 mm
Hardness of tread	D 40 Shore

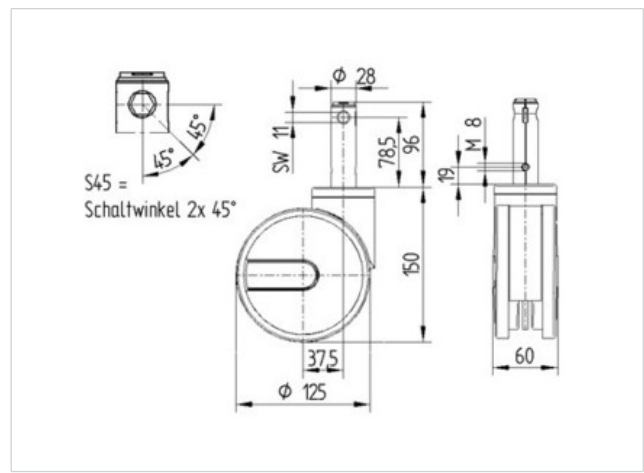

Roll performance	+	+	+	+	+
Movement noise	+	+	+	+	+
Attrition	+	+	+	+	+
Corrosion resistance	+	+	+	+	+

