

Product Information



LINEA

5946UAP150R36-32S300H155

EAN 4031582338928

Swivel castor with central lock, housing made of Polyamide, precision ball bearing in swivel head. Wheel centre made of Polyamide, Tread: Polyurethane, precision ball bearing, stem with cam hole for profile bars, short version

Hint: TÜV Süd certified product.

Technical Data	
Wheel diameter	150 mm
Width of Tread	15 mm
Castor width	71 mm
Bolt-Ø	32 mm
Bolt length	50 mm
Offset	47.5 mm
Swivel Interference	245 mm
Overall height	155 mm
Temperature	- 10 / + 40 °C
Standard	EN 12531
Weight	1.1 kg
Load capacity	150 kg
Load capacity (static)	300 kg
Swivel Radius	122.5 mm

Roll performance	+	+	+	+	+
Movement noise	+	+	+	+	+
Attrition	+	+	+	+	+
Corrosion resistance	+	+	+	+	+

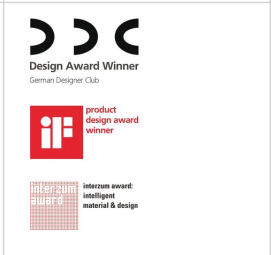
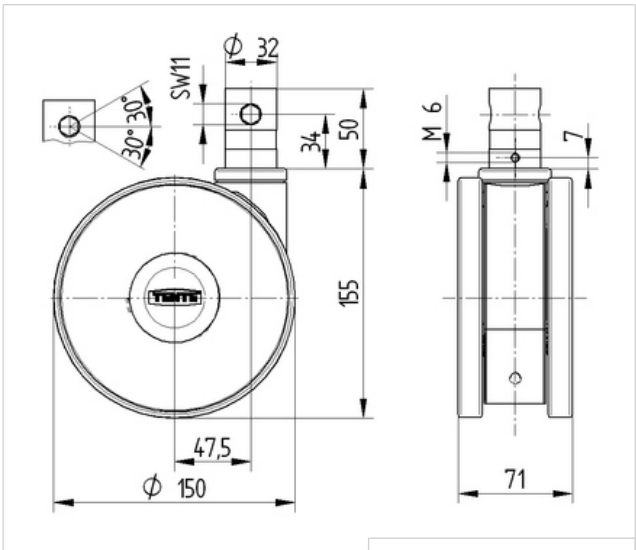

Product Information



LINEA

5946UAP150R36-32S30OH155

EAN 4031582338928

