

Product Information



LINEA

5940UAP100P30-11 RAL9002

EAN 4031582338706

Swivel castor, housing made of Polyamide, precision ball bearing in swivel head. Wheel centre made of Polyamide, Tread: Polyurethane, precision ball bearing, bolt hole

Technical Data	
Wheel diameter	100 mm
Width of Tread	20 mm
Castor width	82 mm
Centre hole	11 mm
Dome-Ø	52 mm
Offset	32 mm
Swivel Interference	164 mm
Overall height	119 mm
Temperature	- 10 / + 40 °C
Standard	EN 12530
Weight	0.682 kg
Load capacity	100 kg
Load capacity (static)	200 kg
Swivel Radius	82 mm
Hardness of tread	A 92 Shore

Roll performance	+	+	+	+	+
Movement noise	+	+	+	+	+
Attrition	+	+	+	+	+
Corrosion resistance	+	+	+	+	+

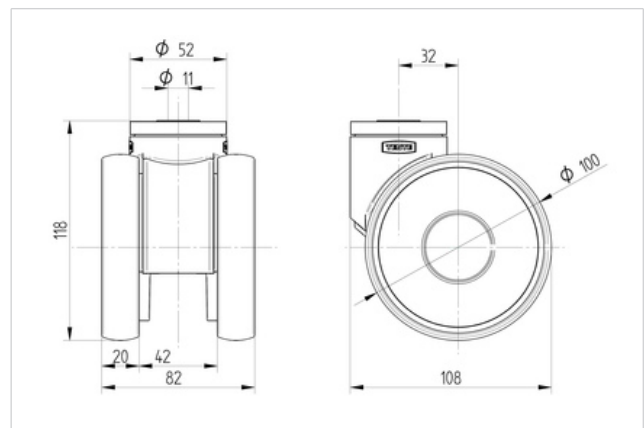

Product Information



LINEA
5940UAP100P30-11 RAL9002
EAN 4031582338706

