

Product Information



4681TOP125P63

EAN 4031582308037

Swivel castor with directional lock, housing made of very heavy pressed steel, reinforced, bright zinc plated, blue passivated, sealed swivel double ball bearing, reinforced and heat-treated ball covers, riveted king pin, wheel axle with nut. Wheel centre made of Polyamide, heavy duty, precision ball bearing, plate fitting

Hint: This castor can be fitted with a directional lock. However, the lock does not come as standard and has to be ordered as an optional extra.



Technical Data	
Wheel diameter	125 mm
Width of Tread	50 mm
Size of Plate	140 x 110 mm
Plate hole centres	105 x 80/74 mm
Plate hole	11 mm
Offset	55 mm
Swivel Interference	230 mm
Overall height	164 mm
Temperature	- 40 / + 80 °C
Standard	EN 12532
Weight	2.834 kg
Load capacity	700 kg
Load capacity (static)	1400 kg
Hardness of tread	D 75 Shore

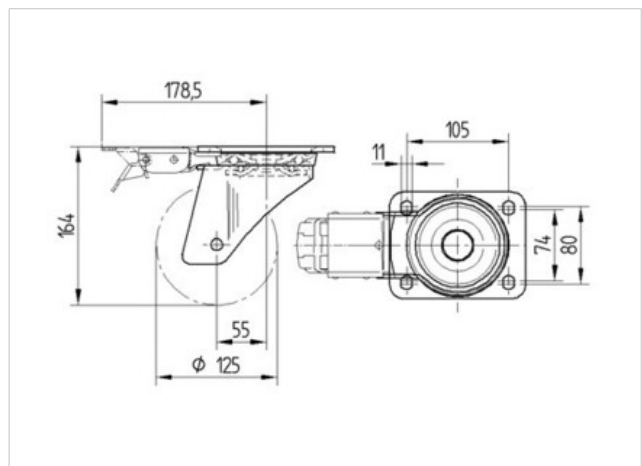

Roll performance	+	+	+	+	+
Movement noise	+	+	+	+	+
Attrition	+	+	+	+	+
Corrosion resistance	+	+	+	+	+

Product Information



4681TOP125P63

EAN 4031582308037

