

# Product Information



## 4687TOP125P63

EAN 4031582308174

Swivel castor with total lock, tail end of castor, housing made of very heavy pressed steel, reinforced, yellow zinc plated, sealed swivel double ball bearing, reinforced and heat-treated ball covers, riveted king pin, wheel axle with nut. Wheel centre made of Polyamide, heavy duty, precision ball bearing, plate fitting



### Technical Data

Wheel diameter	125 mm
Width of Tread	50 mm
Size of Plate	140 x 110 mm
Plate hole centres	105 x 80/74 mm
Plate hole	11 mm
Offset	55 mm
Swivel Interference	360 mm
Overall height	164 mm
Temperature	- 40 / + 80 °C
Standard	EN 12532
Weight	3.102 kg
Load capacity	700 kg
Load capacity (static)	1400 kg
Hardness of tread	D 75 Shore

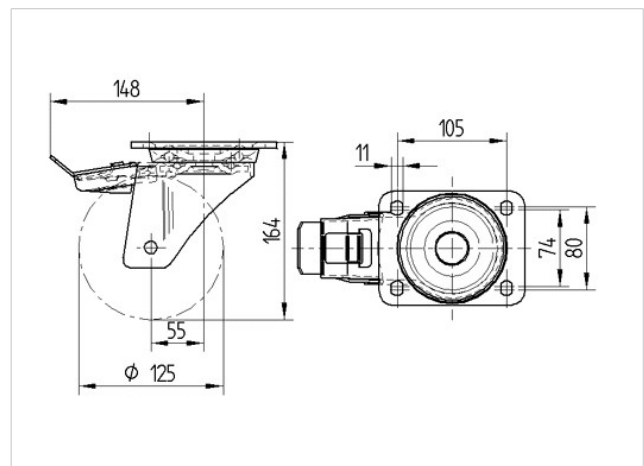

Roll performance	+	+	+	+	+
Movement noise	+	+	+	+	+
Attrition	+	+	+	+	+
Corrosion resistance	+	+	+	+	+



**4687TOP125P63**

EAN 4031582308174

