

## 4687ITP125P63 Flat

EAN 4031582050561

Swivel castor with total lock, tail end of castor, housing made of very heavy pressed steel, reinforced, bright zinc plated, blue passivated, sealed swivel double ball bearing, reinforced and heat-treated ball covers, riveted king pin, wheel axle with nut. Wheel centre made of Aluminium, Tread: Polyurethane, casted, precision ball bearing, plate fitting



Technical Data	
Wheel diameter	125 mm
Width of Tread	50 mm
Size of Plate	140 x 110 mm
Plate hole centres	105 x 80/74 mm
Plate hole	11 mm
Offset	55 mm
Swivel Interference	235 mm
Overall height	164 mm
Temperature	- 20 / + 60 °C
Standard	EN 12532
Weight	3.116 kg
Load capacity	500 kg
Load capacity (static)	1000 kg
Hardness of tread	A 92 Shore

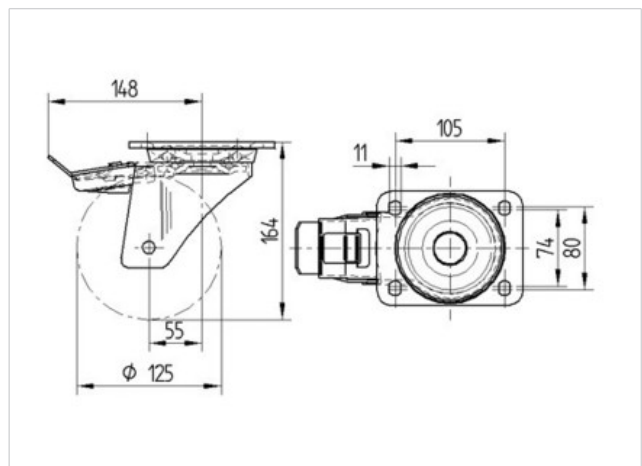

Roll performance	+	+	+	+	+
Movement noise	+	+	+	+	+
Attrition	+	+	+	+	+
Corrosion resistance	+	+	+	+	+



## 4687ITP125P63 Flat

EAN 4031582050561

